

Flood Water Sensor PAT15



The flood sensor PAT15 has flood, based on Z-Wave™ technology. It is the Z-Wave™ plus product, it support the security, OTA... Those newest features of the Z-Wave™ technology. Z-Wave™ is a wireless communication protocol designed for home automation, specifically to remotely control applications in residential and light commercial environments. The technology uses a low-power RF radio embedded or retrofitted into home electronics devices and systems, such as lighting, home access control, entertainment systems and household appliances.

This product can be included and operated in any Z-Wave™ network with other Z-Wave™ certified devices from other manufacturers and/or other applications. All non-battery operated nodes within the network will act as repeaters regardless of vendor to increase reliability of the network.

The device adopt the Z-Wave™ 700 series chip, when your Z-Wave™ network system is all made by Z-Wave™ 700 series devices. The network system will have the advantages as below.

- Concurrent multi-channel support reduces external interference.
- Better RF range, improve about 10 meters in indoor.
- Support 100 Kbps transmit speed, speed up communication.

Specification

Rated	3VDC (CR123A lithium battery)
Battery life	20 years
RF distance	Min. 40M indoor, 100M outdoor line of sight,
RF Frequency	868.40 MHz, 869.85 MHz(EU) 908.40 MHz, 916.00 MHz(US) 920.9MHz, 921.7MHz, 923.1MHz (TW/KR/Thai/SG)
RF Maximum Power	+10dBm (Peak), -10dBm (Average)
Dimension	85(L)x28(W)x23(H)mm
Location	indoor use only
Operation temperature	-20°C to 50°C
Humidity	85%RH max
FCC ID	RHHPAT15

- ✧ Specifications are subject to change and improvement without notice.
- ✧ Indication of battery life : Flood Alarm Report:1 times/month, Auto Report: 4 times/ Day, Auto Wake up 1 time/ Day.

Troubleshooting

Symptom	Cause of Failure	Recommendation
The device can not join to Z-Wave™ network	The device may in a Z-Wave™ network.	Exclude the device then include again.

For Instruction to [http:// www.philio-tech.com](http://www.philio-tech.com)



Battery Installation

When the device report the low battery message. The user should replace the battery to new one. The battery type is CR123A, 3.0V. The way to open the front cover please press the top position, to release the cover.

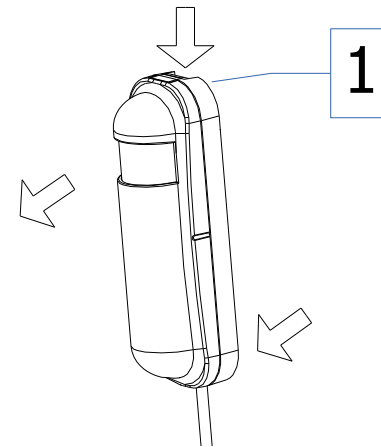

Replace the new battery and install the cover back.

1. Put the front cover bottom, and press down.
2. Push the front cover top.

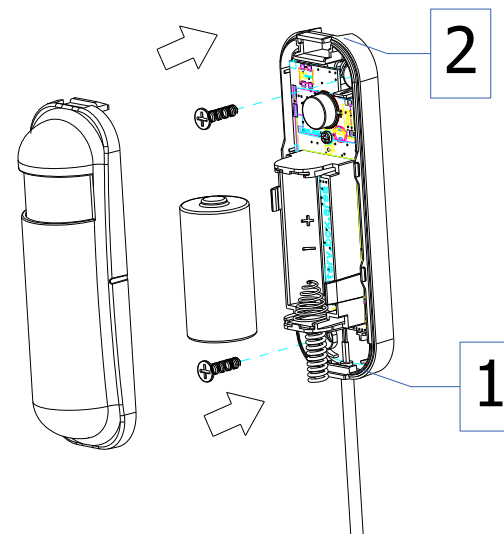

CAUTION

- replacement of a battery with an incorrect type that can defeat a safeguard (for example, in the case of some lithium battery types);
- disposal of a battery into fire or a hot oven, or mechanically crushing or cutting of a battery, that can result in an explosion;
- leaving a battery in an extremely high temperature surrounding environment that can result in an explosion or the leakage of flammable liquid or gas;
- a battery subjected to extremely low air pressure that may result in an explosion or the leakage of flammable liquid or gas

The marking information is located at the bottom of the apparatus.

Overview

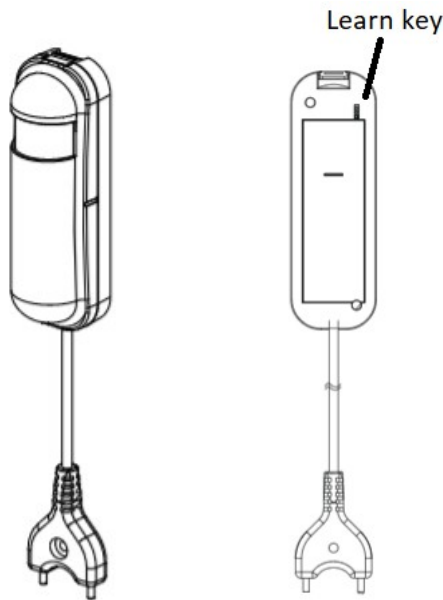

Add to/Remove from Z-Wave™ Network

There are one tamper keys in the back side of the device, It can add, remove, reset or association from the Z-Wave™ network.

In the first time, add the device into the Z-Wave™ network. First, make sure the primary controller is in the add mode. And then power on the device, just take out the insulation Mylar in the back side of the device. The device will auto start the SmartStart Include mode.

Notice: Including a node ID allocated by Z-Wave™ Controller means "Add" or "Inclusion". Excluding a node ID allocated by Z-Wave™ Controller means "Remove" or "Exclusion".

Function	Description
Add	<ol style="list-style-type: none">1. Have Z-Wave™ Controller entered inclusion mode.2. Pressing the tamper key three times within 1.5 seconds to enter the inclusion mode.3. After add successful, the LED will light ON 1 second.
Remove	<ol style="list-style-type: none">1. Have Z-Wave™ Controller entered exclusion mode.2. Pressing tamper key three times within 1.5 seconds to enter the exclusion mode.3. Node ID has been excluded.
Reset	<p>Notice: Use this procedure only in the event that the primary controller is lost or otherwise inoperable.</p> <ol style="list-style-type: none">1. Pressing tamper key four times within 1.5 seconds and do not release the tamper key in the 4th pressed, and the LED will light ON.2. After 3 seconds the LED will turn OFF, after that within 2 seconds, release the tamper key. If successful, the LED will light ON one second. Otherwise, the LED will flash once.

	<p>3. IDs are excluded and all settings will reset to factory default.</p>
SmartStart	<p>1. Product has a DSK string, you can key in first five digit to increment SmartStart process, or you can scan QR code.</p> <p>Ex : mydsk <u>10209</u>-46687-52248-13629-04783-07465-15776-56519</p> <p>2. SmartStart enabled products can be added into a Z-Wave network by scanning the Z-Wave QR Code present on the product providing SmartStart inclusion. No further action is required and the SmartStart product will be added automatically within 10 minutes of minutes On in the network vicinity.</p> <p>* notice1:The QR code can be found on the device PAT15 or on the box.</p>
Association	<p>This machine provides two groups of nodes. Group 1 can set 1 Nodes. Group 2 can set 5 Nodes.</p> <p>Group 1 is called Lifeline the device will report :</p> <ol style="list-style-type: none"> 1.Notification report 2.Device Reset Locally Notification 3.Battery Report 4.Indicator Report <p>Group 2 is called Basic set the device will report :</p> <ol style="list-style-type: none"> 1.Basic Set
	<ul style="list-style-type: none"> • Failed or success in add/remove the node ID can be viewed from Z-Wave™ Controller.

Notice 1: Always RESET a Z-Wave™ device before trying to add it to a Z-Wave™ network

Z-Wave™ Notification

After the device adding to the network, it will wake-up once per day in default. When it wake-up it will broadcast the "Wake Up Notification" message to the network, and wake-up 10 seconds for receive the setting commands.

The wake-up interval minimum setting is 30 minutes, and maximum setting is 120 hours. And the interval step is 30 minutes.

Press the tamper key once. The device will wake-up 10 seconds.

Z-Wave™ Message Report

In default the device will using Notification Report to represent the tamper trigger and flood trigger event.

* Flood Report:

When the flood triggered, the device will unsolicited to send the report to the nodes in the group 1.

Notification Report (V8)
Notification Type: Water Alarm (0x05) Event: Water Leak detected, Unknown Location (0x02)

And after the flood trigger clear, the device will unsolicited to send the report to the nodes in the group 1.

Notification Report (V8)
Notification Type: Water Alarm (0x05) Event: 0x00

* **Tamper Report:**

The tamper key pressed over 5 seconds. The device will into the alarm state. In that state, if the tamper key be released, the device will unsolicited to send the report to the nodes in the group 1.

Notification Report (V8)
Notification Type: Home Security (0x07) Event: Tampering. Product covering removed (0x03)

* **Timing Report:**

Beside the event triggered could report message, the device also support the timing unsolicited report of the status.

- Battery level report: Every 6 hours report once in default. It could be changed by setting the configuration NO. 1.
- Low battery report: When the battery level is too low, every 30 minutes will report once.
- Flood state report: Every 6 hours report once in default. It could be changed by setting the configuration NO. 5.

Notice : The configuration NO. 1 could change the tick interval, the default value is 60, if setting to 1, that means the minimum auto report interval will be one minute.

Power Up Procedure

* **Battery Power Check**

When the device power up, the device will detect the power level of the battery immediately. If the power level is too low, the LED will flash three times. Please change another new battery.

* **Wake**

When the device power on, the device will wake about 20 seconds. In this duration, the controller can communicate with the device. Normally the device is always sleeping to save the battery energy.

Over The Air (OTA) Firmware Update

The device support the Z-Wave firmware update via OTA.

Let the controller into the firmware update mode, and then press the tamper key once to start the update.

After finish the firmware download, ***please don't remove the battery***, otherwise it will cause the firmware broken, and the device will no function.

After the LED stop flash, it is recommended that the user power up the device. **Caution:** After remove the battery, please wait about 30 seconds, and then re-install the battery.

Installation

1. To mount the device on the wall, you can choose using the tape, or the screw.
2. Using the screw to fix the flood detector.

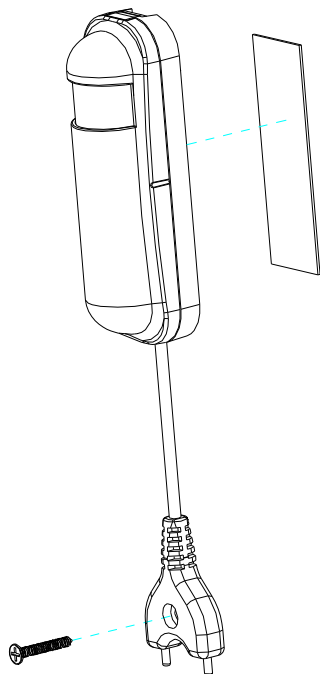

Warning:

1. Before the product is installed, please make sure the surface is clean. Especially for the surface of glass and wood, keep it dry before installation.
2. It is highly recommended to press the product on double-sided tape for 30 seconds.

Z-Wave Configuration Settings

Notice:

- * All of the configuration, the data size is 1.
- * All of the configuration after the remove the setting still keep, don't reset to factory default. Unless the user execute the "RESET" procedure.
- * The reserve bit or not supported bit is allowed any value, but no effect.

NO.	Name	Def.	Valid	Description
1	Auto Report Tick Interval	60	1 ~ 0xFF	The interval time for auto report each tick.(unit:minute)
2	Auto Report Battery Time	6	1 ~ 0xFF	The interval time for auto report the battery level.
3	Customer Function	13	All	Operation mode. Using bit to control.
		1		Bit0: Disable auto report battery function. 0 : Disable / 1 : Enable
		0		Bit1: Reserve.
		1		Bit2: Disable auto report flood function. 0 : Disable / 1 : Enable
		1		Bit3: Turn off the beep sound. 0 : Disable the beep sound. 1 : Enable the beep sound.
		0		Bit4: Reverse flood signal. 1 : Reverse Mode, Short → Not trigger, Open → Trigger. 0 : Normal Mode, Short → Trigger,

NO.	Name	Def.	Valid	Description
				Open → Not trigger.
		0		Bit5: Reserve.
		0		Bit6: Reserve.
		0		Bit7: Reserve.
4	Basic ON Level	0xFF	All	Setting the BASIC command value. When the flood trigger on(0xFF), send the BASIC CC to the group 2.
5	Auto Report Flood State	6	All	The interval time for auto report the flood state.

Firmware Update Meta Data	5	Highest granted Security Class
Indicator	3	Highest granted Security Class
Manufacturer Specific	2	Highest granted Security Class
Multi-Channel Association	3	Highest granted Security Class
Powerlevel	1	Highest granted Security Class
Version	3	Highest granted Security Class
Configuration	4	Highest granted Security Class
Notification	8	Highest granted Security Class
Battery	1	Highest granted Security Class

Z-Wave Supported Command Class

Command Class	Version	Required Security Class
Z-Wave Plus™ Info	2	None
Security	1	None
Security 2	1	None
Supervision	1	None
Transport Service	2	None
Association	2	Highest granted Security Class
Association Group Information	3	Highest granted Security Class
Device Reset Locally	1	Highest granted Security Class

Disposal



This marking indicates that this product should not be disposed with other household wastes throughout the EU. To prevent possible harm to the environment or human health from uncontrolled waste disposal, recycle it responsibly to promote the sustainable reuse of material resources. To return your used device, please use the return and collection systems or contact the retailer where the product was purchased. They can take this product for environmental safe recycling.

Philio Technology Corporation
8F., No.653-2, Zhongzheng Rd., Xinzhuang Dist., New Taipei City
24257, Taiwan(R.O.C)
www.philio-tech.com

FCC Interference Statement

This equipment has been tested and found to comply with the limits for a Class B digital device, pursuant to Part 15 of the FCC Rules.

These limits are designed to provide reasonable protection against harmful interference in a residential installation.

This equipment generates, uses, and can radiate radio frequency energy and, if not installed and used in accordance with the instructions, may cause harmful interference to radio communications.

However, there is no guarantee that interference will not occur in a particular installation.

If this equipment does cause harmful interference to radio or television reception, which can be determined by turning the equipment off and on, the user is encouraged to try to correct the interference by one of the following measures:

- Reorient or relocate the receiving antenna.
- Increase the separation between the equipment and receiver.
- Connect the equipment into an outlet on a circuit different from that to which the receiver is connected.
- Consult the dealer or an experienced radio/TV technician for help.

This device complies with Part 15 of the FCC Rules. Operation is subject to the following two conditions:

1. This device may not cause harmful interference, and
2. This device must accept any interference received, including interference that may cause undesired operation.

FCC Caution: Any changes or modifications not expressly approved by the party responsible for compliance could void the user's authority to operate this equipment.

This transmitter must not be co-located or operating in conjunction with any other antenna or transmitter.

警語:

「取得審驗證明之低功率射頻器材，非經核准，公司、商號或使用者均不得擅自變更頻率、加大功率或變更原設計之特性及功能。

低功率射頻器材之使用不得影響飛航安全及干擾合法通信；經發現有干擾現象時，應立即停用，並改善至無干擾時方得繼續使用。

前述合法通信，指依電信管理法規定作業之無線電通信。低功率射頻器材須忍受合法通信或工業、科學及醫療用電波輻射性電機設備之干擾。」