

# In Wall Micro Switch PAN33



## Introduction

This product can be operated in any Z-Wave network with other Z-Wave certified devices from other manufacturers. All mains operated nodes within the network will act as repeaters regardless of vendor to increase reliability of the network. Mini size design let the module can easily hide itself into the wall box and that will be good for the house decoration.

There are many kind of application by using the module to switch Load On and Off, one main application is the light control. The new smart relay calibration technology can reduce the inrush current caused by the load and let the module work perfectly with many kind of light like incandescent, fluorescent and LED light.

## Safety Precautions and Installation

- Avoid installing the unit in storming or raining weather.
- Be sure to isolate or switch off power source before installing or maintenance.
- Do ensure that the power supply circuit protected by a 16A circuit breaker or suitable equivalent fuse.

## IMPORTANT

- Installation must be performed by skilled technicians who are informed about the standards and technical requirements of the appliance and its proper installation.
- Check your local codes as they apply to your situation. If the house wiring is of aluminum, consult with an electrician about proper wiring methods.

Before proceeding with the installation, TURN OFF THE POWER TO THE LIGHTING CIRCUIT AT THE CIRCUIT BREAKER OR FUSE BOX TO AVOID ELECTRICAL SHOCK.

## Specification

Operating Voltage	100 -240VAC 50Hz-60Hz
Maximum Load	Max. 6.5A (230Vac/120Vac) (Resistive load)
Range	Minimum 40m indoor 100m outdoor line of sight
Operating Temperature	0°C to 40°C
Humidity	Up to 85% max.
Storage Temperature	-20°C to 60°C
Location	Indoor use only
Frequency Range	868.40MHz; 869.85MHz (EU) 908.40MHz; 916.00MHz (USA/Canada) 920.90 MHz, 921.70 MHz, 923.10 MHz (Taiwan)
RF Maximum Power	+10dBm (Peak), -10dBm (Average)
OTA	Support
FCC ID	RHHPAN33
Dimensions	47.5 x 39 x15.6 mm
Wire	0.75mm <sup>2</sup> , 18AWG

\*\* Specifications are subject to change and improvement without notice.

## Troubleshooting

Symptom	Cause of Failure	Recommendation
The Switch not working and LED off	1. The Switch is not connect to the Main power 2. The Switch break down	1. Check power connections 2. Don't open up the Switch and send it for repair.
The Switch LED	Check if the load connect	Set the ON/OFF switch of the

illuminating, but cannot control the ON/OFF Switch of the attached load	into the Switch has its own ON/OFF switch	attached load to ON
The Switch LED illuminating, but the detector cannot control the Switch	1. Not carry out association 2. Same frequency interference	1. Carry out association 2. Wait for a while to re-try
LED keep flashing continuously, but cannot control	Overload occurs	Remove the attached load or check max. load cannot exceed 85°C (230Vac/120Vac) (Resistive load)

### Installation Steps

1. Connect PAN33 to AC N and L.
2. Connect Load to NO1.
3. Connect external Switch S1 and S2 to L.

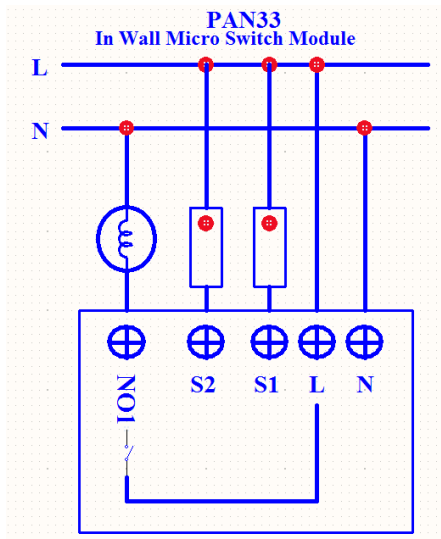
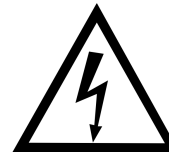

Fig 1. Assembling and wiring

For Instruction to [http:// www.philio-tech.com](http://www.philio-tech.com)



**DANGER**  
Danger of electrocution!

All works on the device may be performed only by a qualified and licensed electrician. Observe national regulations.

**Any works introducing changes into the configuration must be always performed with disconnected voltage.**

Choosing a Suitable Location

1. Do not locate the Module facing direct sunlight, humid or dusty place.
2. The suitable ambient temperature for the Module is 0°C~40°C.
3. Do not locate the Module where exists combustible substances or any source of heat, e.g. fires, radiators, boiler etc.
4. After putting it into use, the body of Module will become a little bit hot of which phenomenon is normal.

## Adding to Z-Wave™ Network

In the front casing, there is an on/off button with LED indicator below which is used to toggle switch on and off. The table below lists an operation summary of basic Z-Wave functions. Please refer to the instructions for your Z-Wave™ Certified Primary Controller to access the Setup function, and to include/exclude/reset devices

Function	Description	LED Indication
No node ID	The Z-Wave Controller does not allocate a node ID to the Switch.	2-second on, 2-second off
Add (Inclusion)	Have Z-Wave Controller entered inclusion mode.	One press one flash ※ To support handling of the device when already installed the external switch can be used for inclusion or exclusion for 3 minutes after power up.
	Pressing Include button of PAN33 three times within 2 seconds will enter inclusion mode.	
SmartStart	<ol style="list-style-type: none"> <li>To initiate the SmartStart process, please type in the first five digits of DSK string or scan the QR code. The QR Code can be found on PAN33 or in the box. Ex: DSK: 18112-24021-58001-62259-57092-27453-08187-47408</li> <li>PAN33 is supported with SmartStart, it can be added to Z-Wave™ network by scanning the Z-Wave™ QR code on the product.</li> <li>Without further actions, PAN33 will be automatically included in a certified Z-Wave™ Controller with SmartStart inclusion ability in 10 minutes after it turned on.</li> </ol>	
Remove (Exclusion)	Have Z-Wave Controller entered exclusion mode.	One press one flash ※ To support handling of the device when already installed the external switch can be used for inclusion or exclusion for 3 minutes after power up.
	Pressing Include button of PAN33 three times within 2 seconds will enter exclusion mode.	
	Node ID has been excluded.	2s On, 2s Off (No node ID)
Reset	Pressing Include button of PAN33 three times within 2 seconds will enter inclusion mode.	One press one flash

Within 1 second, press Include button of PAN33 again for 5 seconds.

IDs are excluded.

2s On, 2s Off (No node ID)

- ※ Adding a node ID allocated by Z-Wave Controller means inclusion. Removing a node ID allocated by Z-Wave Controller means exclusion.
- ※ Failed or success in including/excluding the node ID can be viewed from the Z-Wave Controller.
- ※ Sometimes people are not easy to execute exclusion or inclusion especially when PAN33 already installed in a wall box. To solve this issue, PAN33 support a special feature that can use S1 or S2 to execute "exclusion, inclusion, Reset or Association" at the first 3 minutes when first time connect to main power.

## LED Indication

There is a LED for identify function in the front case. PAN33 support the indicator ID 0x50 (Identify) and Properties ID 0x03, 0x04 and 0x05. To distinguish what mode the switch is in, view from the LED for identification.

State Type	LED Indication
Normal	When PAN33 switch On the LED will lights up, when PAN33 switch Off the LED will lights off.
No node ID	Under normal operation, when the Switch has not been allocated a node ID, the LED flashes on and off alternately at 2-second intervals.
Overload	When overload state occurs, the Switch is disabled of which LED flashes on and off alternately at 0.2 second intervals. Overload state can be cleared by disconnect and reconnect the Switch to the main power.

## Installation

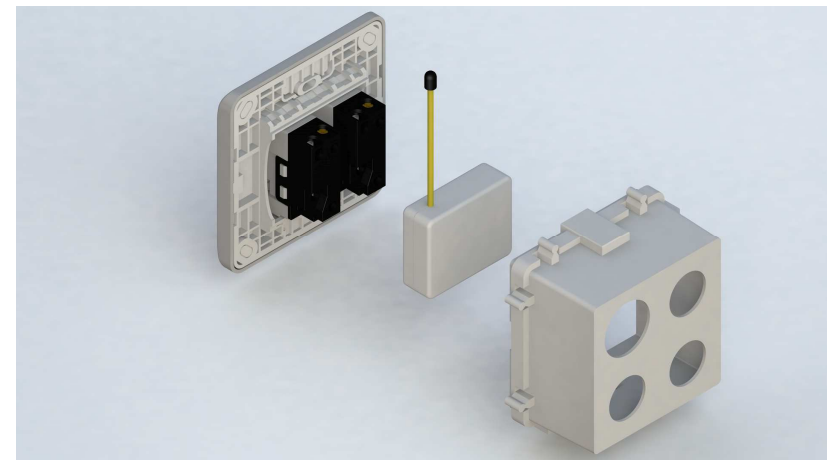

1. Put the in wall switch into a wall box and connect the AC power wire L, N to PAN33 connector L, N.
2. Connect the wall switch to the PAN33 as Fig1.
3. There are 3 mode PAN33 can be configured to match different kind of wall switch, please refer to **3-1 External switch mode** which described in next section of this user manual
4. If Edge-Toggle mode has been set, and the S1/S2 is connect to normal bi-stable switch, every time when change the state of the wall switch will also swap the state of Relay1.

## Programming

### 1. Basic Command Class / Binary Switch Command Class

The Switch will respond to BASIC and BINARY commands that are part of the Z-Wave system.

#### 1-1 BASIC\_GET / BINARY\_SWITCH\_GET

PAN33 will report ON when relay 1 is ON, or report OFF when relay1 is OFF.

Basic Get Command: <b>[Command Class Basic, Basic Get]</b>
Basic Report Command: Report OFF: <b>[Command Class Basic, Basic Report, Value = 0(0x00)]</b> Report ON: <b>[Command Class Basic, Basic Report, Value = 255(0xFF)]</b>

Binary Switch Get Command: <b>[Command Class Switch Binary, Switch Binary Get]</b>
Binary Switch Report Command: Report OFF: <b>[Command Class Switch Binary, Switch Binary Report, Value =0(0x00)]</b> Report ON: <b>[Command Class Switch Binary, Switch Binary Report, Value = 255(0xFF)]</b>

#### 1-2 BASIC\_SET / SWITCH\_BINARY\_SET

PAN33 will turn on or off upon receipt of the following commands from a Z-Wave Controller.

<b>[Command Class Basic, Basic Set, Value = 1~99, 255(0xFF)]</b> : both the load attached to the Switch turns on.
<b>[Command Class Basic, Basic Set, Value = 0(0x00)]</b> : both the load attached to the Switch turns off.

<b>[Command Class Switch Binary, Switch Binary Set, Value = 1~99, 255(0xFF)]</b> : both the load attached to the Switch turns on.
<b>[Command Class Switch Binary, Switch Binary Set, Value = 0(0x00)]</b> : both the load attached to the Switch turns off.

### 1. Z-Wave's Groups (Association Command Class Version 2)

The Switch can be set to send reports to the associated Z-Wave devices. It supports one groups and every group has five nodes support. Group1 is called Lifeline which support SWITCH\_BINARY\_REPORT · NOTIFICATION\_REPORT · INDICATOR\_REPORT and DEVICE\_RESET\_LOCALLY\_NOTIFICATION.

#### 2-1 Auto report to Grouping 1(Maximum Node 5)

##### 2-1-1 On/Off Event Report

When "on" or "off" state has been changed (ex. Press S1 or S2 or include on/off button), it will send Binary Switch Report to the nodes of Group1.

Binary Switch Report

ON: <b>[Command Class Switch Binary, Switch Binary Report, Value =255(0xFF)]</b>
OFF: <b>[Command Class Switch Binary, Switch Binary Report, Value =0(0x00)]</b>

##### 2-1-2 Overload Notification report command

When PAN33 detect the overload, it will send Notification Report to Group1.

The content of Notification Report

Notification report command: <b>[Command Class Notification, Notification Report, Notification Type = 0x08, Event state = 0x08]</b>
---

### 2. Z-Wave's Configuration

Configuration Parameter	Function	Size (Byte)	Value	Unit	Default	Description
1	External switch mode	1	1-3		1	1 : Edge mode 2 : Pulse mode 3 : Edge-Toggle mode
2	Restore switch state mode	1	0-2		1	0 : Switch off 1 : Last switch

						state 2 : Switch on
3	Manual On/Off mode	1	0-1		1	0 : Disable manual On/Off 1 : Enable manual On/Off
4	LED indication mode	1	1-3		1	1 : Show switch state 2 : Show night mode 3 : One flash mode
5	Manual Switch Report mode	1	0-1		1	0 : Disable 1 : Enable

### 3-1 External switch mode

Manual switch S1 and S2 can set to Edge mode or Pulse mode or Edge-Toggle mode, default value is Edge mode.

**Edge mode:** this mode is suitable for the [bi-stable](#) wall switch that has indicator point on the switch, and the same position correspond to same state of relay1. If the PAN33 relay change the state because of receiving Z-Wave RF command, it may need two times of change (switch on to off or switch off to on) to let relay back to the correspond state.

**Pulse mode:** this mode is suitable for the toggle type wall switch to swap the state of Relay1.

**Edge-Toggle mode:** this mode is suitable for the normal bi-stable switch, every time when change the state of the wall switch will also swap the state of Relay1.

### 3-2 Restore switch state mode

Whenever the AC power return from lost, PAN33 will restore the switch state which could be SWITCH OFF · LAST SWITCH STATE · SWITCH ON. The default setting is LAST SWITCH STATE.

### 3-3 Manual On/Off Mode :

The On/Off function of S1 · S2 and learn switch can be disabled or enabled by this parameter, default value is Enable. But the learning operation won't be affected. When manual On/Off function is disabled, the RF command can only switch On but not Off. This is useful function for keeping the device in switch on state.

### 3-4 LED indication Mode:

3-4-1 Show switch state : LED on for switch on and off for switch off. The default value is Show switch state.

3-4-2 Show night mode : LED off for switch on and on for switch off.

3-4-3 One Flash mode : When the state of switch changes, LED will be on only one second, then LED keeps off.

### 3-5 Manual Switch Report mode :

Whenever PAN32 is manually switch on or off, it will send BINARY\_SWITCH\_REPORT to the node of group1. The default setting is Enable the function.

## 5. Firmware update over the air (OTA)

PAN33 is based on 700 series SoC and supports Firmware Update Command Class, it can receives the updated firmware image sent by controller via the Z-wave RF media. It is a helpful and convenient way to improve some function if needed.

## 6. Command Classes

The Switch supports Command Classes including...

Command Class	Version	Required Security Class
Z-Wave Plus Info	2	None
Security 0	1	None
Security 2	1	None

Supervision	1	None
Transport Service	2	None
Association	2	Highest granted Security Class
Association Group Information	3	Highest granted Security Class
Basic	2	Highest granted Security Class
Binary Switch	2	Highest granted Security Class
Configuration	4	Highest granted Security Class
Device Reset Locally	1	Highest granted Security Class
Firmware Update Meta Data	5	Highest granted Security Class
Indicator	3	Highest granted Security Class
Manufacturer Specific	2	Highest granted Security Class
Multi Channel Association	3	Highest granted Security Class
Notification	8	Highest granted Security Class
Powerlevel	1	Highest granted Security Class
Version	3	Highest granted Security Class

## Disposal

	<p>This marking indicates that this product should not be disposed with other household wastes throughout the EU. To prevent possible harm to the environment or human health from uncontrolled waste disposal, recycle it responsibly to promote the sustainable reuse of material resources. To return your used device, please use the return and collection systems or contact the retailer where the product was purchased. They can take this product for environmental safe recycling.</p>
---	---

Philio Technology Corporation

8F.,No.653-2,Zhongzheng Rd., Xinzhuang Dist., New Taipei City 24257,Taiwan(R.O.C)

[www.philio-tech.com](http://www.philio-tech.com)

## FCC Interference Statement

This equipment has been tested and found to comply with the limit's for a Class B digital device, pursuant to Part 15 of the FCC Rules. These limits are designed to provide reasonable protection against harmful interference in a residential installation. This equipment generates, uses and can radiate radio frequency energy and, if not installed and used in accordance with the instructions, may cause harmful interference to radio communications. However, there is no guarantee that interference will not occur in a particular installation. If this equipment does cause harmful interference to radio or television reception, which can be determined by turning the equipment off and on, the user is encouraged to try to correct the interference by one of the following measures:

- Reorient or relocate the receiving antenna.
- Increase the separation between the equipment and receiver.
- Connect the equipment into an outlet on a circuit different from that to which the receiver is connected.
- Consult the dealer or an experienced radio/TV technician for help.

This device complies with Part 15 of the FCC Rules. Operation is subject to the following two conditions:

- (1) This device may not cause harmful interference, and
- (2) This device must accept any interference received, including interference that may cause undesired operation.

FCC Caution: Any changes or modifications not expressly approved by the party responsible for compliance could void the user's authority to operate this equipment.

This transmitter must not be co-located or operating in conjunction with any other antenna or transmitter.

**警語:**

「取得審驗證明之低功率射頻器材，非經核准，公司、商號或使用者均不得擅自變更頻率、加大功率或變更原設計之特性及功能。

低功率射頻器材之使用不得影響飛航安全及干擾合法通信；經發現有干擾現象時，應立即停用，並改善至無干擾時方得繼續使用。

前述合法通信，指依電信管理法規定作業之無線電通信。低功率射頻器材須忍受合法通信或工業、科學及醫療用電波輻射性電機設備之干擾。」