

PAD19 – In Wall Micro Dimmer



Description and features

It can only needs to connect two wires, single wire (L) and load (NO1), or three wires, two wire (L · N) and load (NO1)

This device is a security enabled Z-Wave Plus™ product that uses encrypted Z-Wave Plus™ messages to communicate to other security enabled Z-Wave Plus™ products. Z-Wave™ enabled devices displaying the Z-Wave™ logo can also be used with this device regardless of the manufacturer, and this device can also be used in other manufacturer's Z-Wave™ enabled networks.

All mains operated nodes within the network will act as repeaters regardless of vendor to increase reliability of the network. The product supports an Over the Air (OTA) feature for the products firmware upgrade

- Main features of Philio's In Wall Micro dimmer,
- Compatible with any Z-Wave™ or Z-Wave™ Plus Controller,
- Supports Z-Wave™ network Security Modes: S2,
- To be installed with LED dimmer or incandescent lamp,
- A single live without neutral lead,
- To be installed in-wall switch boxes.

Specification

Operating Rated	100-240Vac 50Hz-60Hz 0.7A
Output load	Max. 0.7A (100-240VAC) 160W (Dimmable LED bulbs or Incandescent lamp)(230Vac) 80W (Dimmable LED bulbs or Incandescent lamp)(120Vac)
Fuse information	Built-in Thermal Cut-off Fuses protection. Rated Temperature :150 °C; Rated: 2A 250V.
LED minimum	Min. 20W for Dimmable LED bulb not flickering
Operating Temperature	0°C - 40°C
Humidity	Up to 85% max
Storage Temperature	-20°C - 60°C
Location	Indoor use only
Frequency Range	868.40MHz, 869.85MHz EU 908.4MHz, 916.0MHz US, 922.5MHz, 923.9MHz, 926.3MHz (JP) 920.9MHz, 921.7MHz, 923.1MHz (TW/KR/Thai/SG)

RF Maximum Power	+10dBm (Peak), -10dBm (Average)
Transmission Range	Up to 40m indoors or up to 100m outdoors (depending on building materials)
OTA	Support
Dimensions	47.5x39x16 mm
Wire	0.75mm ² ; 18AWG

** Specifications are subject to change and improvement without notice.

Troubleshooting

Symptom	Cause of Failure	Recommendation
The dimmer does not work and LED off	1.The dimmer does not connect the electrical wire properly 2.The dimmer break down	1. Check power connections 2. Don't open up the dimmer and send it for repair.
The device can not join to Z-Wave™ network	The device may in a Z-Wave™ network.	Exclude the device then include again.
Flashing during dimming	Minimum load is less than 20W	Replace larger load

Installation steps

There are two wiring methods for PAD19.

- Connect the AC L line and the bulb load end.
- S1 Can be connect externally switches.C. COM is for S1 connect port.

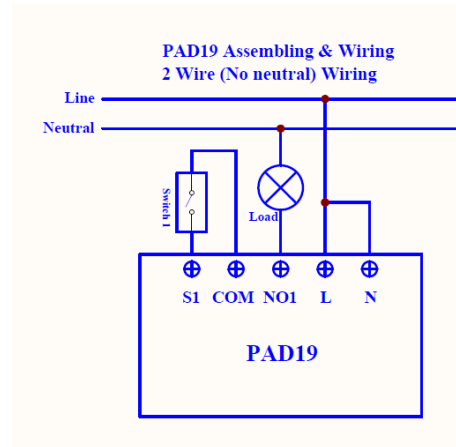

Fig 1. Assembling & Wiring

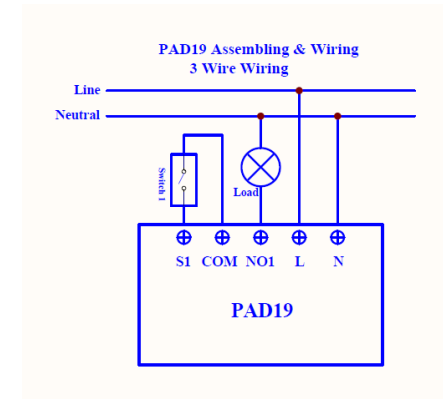

Fig 2. Assembling & Wiring

Important: Read all instructions prior to installation

IMPORTANT

Installation must be performed by skilled technicians who are informed about the standards and technical requirements of the appliance and its proper installation.

Check your local codes as they apply to your situation. If the house wiring is of aluminum, consult with an electrician about proper wiring methods.

Before proceeding with the installation, TURN OFF THE POWER TO THE LIGHTING CIRCUIT AT THE CIRCUIT BREAKER OR FUSE BOX TO AVOID ELECTRICAL SHOCK.

For Instruction to <http://www.philio-tech.com>

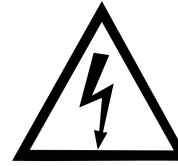
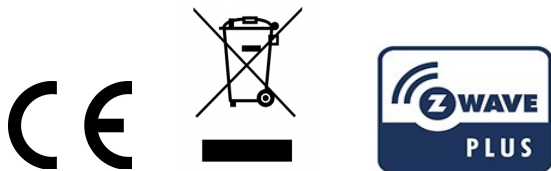

Danger
Danger of electrocution!

All works on the device may be performed only by a qualified and licensed electrician. Observe national regulations. Any works introducing changes into the configuration must be always performed with disconnected voltage.

Choosing a Suitable Location

1. Do NOT place the module/device direct under sunlight, in a humid place or in any location where they may contact moisture, dirt, dust.
2. Do NOT place the module/device where exists combustibile substance or any source of heat, fires, radiators, boiler etc.
3. When the module/device be used, the module/device might get warm. This is a normal condition.
4. After putting it into use. The body of Module will bexome a little bit hot of which phenomenon is normal.

Adding to Z-Wave™ Network

In the front of the device, there is an on/off button with an LED light indicator which is used to dim on and off, carry out inclusion, exclusion, reset or association. When powered for the first time, the device's LED light will flash on and off alternately and repeatedly at 1 second intervals. This implies that no node ID has been assigned, and auto inclusion is ready to start.

This product can be operated in any Z-Wave™ network with other Z-Wave™ certified devices from other manufacturers. All non-battery operating nodes within the network will act as repeaters regardless of the vendor in order to increase reliability of the network.

The table below provides a summary of operations of basic Z-Wave™ functions. Please refer to the instructions for your Z-Wave™ Certified Primary Controller to access the Setup function, and to Add/Remove/associate devices.

Function	Description	Annotation
No node ID	The Z-Wave™ Controller does not allocate a node ID to the Switch.	LED light flashes once every one second and last for 30 seconds.
Add (Classic Inclusion)	1. Put your Z-Wave™ controller into inclusion mode by following the instructions provided by the controller manufacturer.	
	2. Press the include button three times within 3 seconds to enter inclusion mode.	
SmartStart	1. The product has a DSK string. Key in the first five digits to initiate the SmartStart process, or scan QR code. Ex: DSK: 18112-24021- 48001-62259-57092-27453-08187-47408	

	2. SmartStart enabled products can be added into a Z-Wave™ network by scanning the Z-Wave™ QR Code on the product, with a controller providing SmartStart inclusion. No further action is required and the SmartStart product will be added automatically to the closest network within 10 minutes of being switched on. Notice: The QR Code can be found on the device PAD19 or in the box.	
Remove (Exclusion)	1. Put your Z-Wave™ controller into exclusion mode by following the instructions provided by the controller manufacturer.	
	2. Press the include button three times within 3 seconds to enter exclusion mode.	
	3. Node ID will be excluded.	LED light flashes once every one second and last for 30 seconds
Reset	1. Press the include button four times within 3 seconds and hold on the button press without releasing.	LED light will be on status

	2. Keep pressing the button for 3 seconds then LED will be off, release the button within 2 seconds.	
	3. Device has been reset.	LED light flashes once every one second and last for 30 seconds.
<ul style="list-style-type: none"> ● Adding a node ID allocated by Z-Wave™ Controller means inclusion. Removing a node ID allocated by Z-Wave™ Controller means exclusion. ● Failed or success in including/excluding the node ID can be viewed from the Z-Wave™ Controller. ● Function Reset: Please use this procedure only when the network primary controller is missing or otherwise inoperable. 		

LED Light Indication

To identify what mode the switch is in, view the following table for LED light identification.

State Type	LED Indication
No node ID	Under normal operation, when the Switch has not been allocated a node ID, the LED light will flash on and off alternately at 1-second intervals. By pressing the On/Off button, LED light will stop flashing temporarily.
Learning	Flashes when learning is successful

Over-load	LED flashes one time every 0.4 seconds.
-----------	---

Manual dim level control:

Long press the button, the light will increase the lighting slowly.

Short press the button, the light will be on/off.

You can set Z-Wave™ Configuration 1 as value 2,

S1 only increasing the light.

key Type	Config 6 set	Long Press	Short Press
Learn button		DIMMER	ON/OFF
S1	0	DIMMER	ON/OFF
	1	TOGGLE	

Over-load

When overload occurred, device will launch protection mechanism and cut off power of loading. LED will quick flash one time every 0.4 seconds. Device will also send "Over-load detected" as Z-Wave™ Notification. Device will not accept any control until AC off/on.

Z-Wave™ Function

Basic Command Class/Multilevel Switch Command Class

The dimmer will respond to BASIC and MULTILEVEL SWITCH commands that are part of the Z-Wave™ system. If PAD19 is included as a secured node, it will only respond to the security encapsulation command of BASIC and MULTILEVEL SWITCH.

The Basic Command Class is mapped according to the following table.

Basic Command	Mapped Command
Basic Set (Value)	Multilevel Switch Set (Value)
Basic Report (Current Value, Duration)	Multilevel Switch Report (Value, Duration).

Z-Wave™ Association Groups

The PAD19 can be set to send reports to associated Z-Wave™ devices. It supports one association group with five nodes support for group 1.

For group 1, the dimmer will report MULTILEVEL_SWITCH_REPORT, NOTIFICATION_REPORT and DEVICE_RESET_LOCALLY_NOTIFICATION.

1. Grouping 1 Lifeline (Maximum 5 nodes).

2. MULTILEVEL_SWITCH_REPORT

When “on” or “off” state has been changed, it will send Multilevel Switch Report to the nodes of Grouping 1.

3. NOTIFICATION_REPORT

When overload occurred.

4. DEVICE_RESET_LOCALLY_NOTIFICATION

When PAD19 is reset manually, it will send DEVICE_RESET_LOCALLY_NOTIFICATION to the nodes of group 1.

Z-Wave™ configuration

No.	Name	Size (Byte)	Default	Value	Description (Info)
1	Power-on recovery status set	1	0	0~2	To set dimmer level when AC power on. Setting value: 0: OFF-0% 1: ON-last level 2: ON-100%
2	RF report set	1	1	0~1	To set if device send Multilevel Switch report to gateway when dimming finished. Setting value: 1: report ON 0: report OFF
3	Maximum level	1	99	(Minimum level+1)~99	To set dimming level maximum value. Dimming level will not over the setting value. Setting value: Cannot be lower than the Mini-

					imum level
4	Minimum level	1	0	0~(Maximum level-1)	To set dimming level minimum value. Dimming level will directly go to 0% when dimming value is lower than the setting value. Setting value: Cannot be higher than the Maximum level
5	Basic duration set	1	2	0~127	Unit: second To set dimming finished duration time when physical switch used. Ex: When setting is 2, it will take 2 seconds from switch on action to dimming finished.
6	Switch Set	1	1	0~1	0: Long Press:dimmer Short Press:ON/OFF 1: Toggle(no dimmer function)

Notice 1: Always remove a Z-Wave™ device before trying to add it to a Z-Wave™ network.

Notice 2: This product can be operated in any Z-Wave™ network with other Z-Wave™ certified devices from other manufacturers. All non-

battery operated nodes within the network will act as repeaters regardless of vendor to increase reliability of the network.

Over The Air Firmware Update

The device support the Z-Wave™ firmware update via OTA. Let the Z-Wave™ Controller into the firmware update mode, choose the hex file to update. Wait for 10~15 minutes. At that time, ***please don't remove the power***, otherwise it will cause the firmware broken, and the device will no function. Result will show in Z-Wave™ Controller log.

Z-Wave™ Supported Command Class

Command Class	Version	Required Security Class
Z-Wave™ Plus Info	2	None
Security	1	None
Security 2	1	None
Supervision	1	None
Transport Service	2	None
Association	2	Highest granted Security Class
Association Group Information	3	Highest granted Security Class
Device Reset Locally	1	Highest granted Security Class
Firmware Update Meta Data	5	Highest granted Security Class
Indicator	3	Highest granted Security Class
Manufacturer Specific	2	Highest granted Security Class

Multi Channel Association	3	Highest granted Security Class
Powerlevel	1	Highest granted Security Class
Version	3	Highest granted Security Class
Configuration	4	Highest granted Security Class
Notification	8	Highest granted Security Class
Multilevel Switch	4	Highest granted Security Class
Basic	2	Highest granted Security Class

Disposal



This marking indicates that this product should not be disposed with other household wastes throughout the EU. To prevent possible harm to the environment or human health from uncontrolled waste disposal, recycle it responsibly to promote the sustainable reuse of material resources. To return your used device, please use the return and collection systems or contact the retailer where the product was purchased. They can take this product for environmentally safe recycling.

Philio Technology Corporation

8F., No.653-2, Zhongzheng Rd., Xinzhuang Dist., New Taipei City 24257, Taiwan(R.O.C)

www.philio-tech.com

FCC Interference Statement

This equipment has been tested and found to comply with the limits for a Class B digital device, pursuant to Part 15 of the FCC Rules.

These limits are designed to provide reasonable protection against harmful interfer-

ence in a residential installation.

This equipment generates, uses and can radiate radio frequency energy and, if not installed and used in accordance with the instructions, may cause harmful interference to radio communications.

However, there is no guarantee that interference will not occur in a particular installation. If this equipment does cause harmful interference to radio or television reception, which can be determined by turning the equipment off and on, the user is encouraged to try to correct the interference by one of the following measures:

- Reorient or relocate the receiving antenna.
- Increase the separation between the equipment and receiver.
- Connect the equipment into an outlet on a circuit different from that to which the receiver is connected.
- Consult the dealer or an experienced radio/TV technician for help.

This device complies with Part 15 of the FCC Rules. Operation is subject to the following two conditions:

- (1) This device may not cause harmful interference, and
- (2) This device must accept any interference received, including interference that may cause undesired operation.

FCC Caution: Any changes or modifications not expressly approved by the party responsible for compliance could void the user's authority to operate this equipment.

This transmitter must not be co-located or operating in conjunction with any other antenna or transmitter.

警語:

「取得審驗證明之低功率射頻器材，非經核准，公司、商號或使用者均不得擅自變更頻率、加大功率或變更原設計之特性及功能。」

低功率射頻器材之使用不得影響飛航安全及干擾合法通信；經發現有干擾現象時，應立即停用，並改善至無干擾時方得繼續使用。

前述合法通信，指依電信管理法規定作業之無線電通信。低功率射頻器材須忍受合法通信或工業、科學及醫療用電波輻射性電機設備之干擾。」